



REGULAR ARTICLE

Vanadium Dioxide-assisted Dual Band Polarization-insensitive Metamaterial Absorber for Terahertz Applications

Mahesh Valathuru¹, Pokkunuri Pardhasaradhi^{1,*}, Suresh Dannana^{2,†},
Nagandla Prasad², B.T.P. Madhav¹, Sudipta Das³

¹ ALRC Research Centre, Department of ECE, Koneru Lakshmaiah Education Foundation, Guntur, Andhra Pradesh, India

² Department of Electronics and Communication Engineering, GMR Institute of Technology, Rajam, 532127 Andhra Pradesh, India

³ Department of Electronics and Communication Engineering, IMPS College of Engineering and Technology, Malda 732103 West Bengal, India

(Received 12 February 2025; revised manuscript received 18 April 2025; published online 28 April 2025)

The purpose of this research is to provide a thorough design and analysis of vanadium dioxide (VO₂)-based THz metamaterial absorbers. The three-layer designs of the proposed metamaterial absorbers (MMAs) include a radiating element of vanadium dioxide (VO₂) with 0.2 μm thick, a dielectric substrate of polyimide with a dielectric constant of 3.5, and a ground conducting layer of gold (Au) with an electrical conductivity of 4.56e + 07 S/m to prevent electromagnetic wave propagation. The overall size of the proposed structure is 34 × 36 × 7.4 μm³. The two absorption peak frequencies at which the unit cell MMA operates are 4.4 THz and 9.68 THz. The maximum absorption percentages in the operating frequency ranges are 96 % and 98 %, and they span from 4 to 4.8 THz and 9.5 to 11.4 THz respectively. It is highly advantageous to comprehend the conductive phenomena of the VO₂ radiating patch to achieve a high percentage absorption for the relevant absorption frequency band. Moreover, the insensitivity of absorptance to the polarization angle is verified. Additionally, parametric analysis is performed for various design parameters on the absorption response of suggested absorber. Furthermore, the impact of polarization angle on absorptance for TE and TM modes is presented. The prescribed dual band terahertz absorber could be suitable for cloaking, imaging, detection and electromagnetic shielding.

Keywords: Absorber, Metamaterial, Vanadium dioxide (VO₂).

DOI: [10.21272/jnep.17\(2\).02021](https://doi.org/10.21272/jnep.17(2).02021)

PACS numbers: 78.67.Pt, 87.50.U

1. INTRODUCTION

Terahertz wave manipulations have garnered increasing interest because of their wide range of possible applications in radar stealth, biological imaging, and wireless communication [1]. To set the groundwork for enhancement of 6G communications proposed in [2]. In the 6G frequency band, the lack of functioning devices with exceptional features is the main issue affecting the implementation of optic-systems. The primary reason for this is the shortage of natural materials capable of direct interaction with terahertz waves. The artificially developed electromagnetic composite material known as meta surfaces has shown significant promise for use in the lens typed metals, perfect absorbers [3], and converters to overcome this issue. Instead of the substances that make them up, these impacts are mostly caused by their unit structures [4]. As everyone is aware, photonic crystals are made up of many films, each of which has a refractive index that fluctuates periodically in space. This allows for the elimination of interference through multiple reflections. This is ac-

complished by selectively transmitting (reflecting) light by cancelling out specific light frequency bands. A surface containing microstructures can be utilized to achieve thinness and lightness while reducing the number of artificial material layers and preserving interference cancellation. The addition of metasurface to crystalline to improve absorptance percentage [5] or thinner oxide films to provide adjustable characteristics has also been reported.

For example, in the microwave region, a metamaterial absorber with perfect absorption was proposed by Landy et al. [6]. A strong basis for the enhancement of weightless, incredibly thin absorbers is established by the fact that its thickness is just 1/25 of the resonance wavelength [7]. A terahertz absorber with a 90 % bandwidth and a bandwidth from 1.85 to 4.3 THz was proposed by Huang et al. [8], which consist of multiple VO₂ squared patches. A multi-band absorber with three perfect absorption peaks in the THz regime was developed by Pan et al. using a ring-shaped array made of graphene [9]. A switchable absorber-based VO₂ that can

* Correspondence e-mail: pspokkunuri@kluniversity.in

† suresh.d@gmrit.edu.in



transition between reflection and absorption with 0.67 THz bandwidth was proposed by Ding et al. [10]. Ren et al. [11] developed a thermally switched absorber for circularly polarized light in the infrared range that can accomplish complete absorption and asymmetric transmission using a phase-change material VO₂. The novel metamaterial proposed by Xiaojun Huang [12] is composed of gold conducting ground and polyimide as middle layer. It has an absorptance of over 90 % [15-17] in the 0.86-3.54 THz range with a fractional bandwidth of 121.8 %, which offers potential uses in energy harvesting, terahertz detection [13], clocking and switches [14].

Although many novel designs of ideal absorbers have been developed, there is a gap between the performance of dual band absorbers for various applications. To improve the percentage of absorption at resonance, we designed a low-profile THz MMA with a simple design and higher absorption peaks at resonance. One of the most important aspects of the conventional three-layer absorber is the material and structure of the top layer design. The proposed structure operates at two resonant frequencies and achieves absorptions of 96 % and 98 %, respectively.

2. DESIGN METHODOLOGY OF MMA

The proposed structure was modelled using computational modelling such as CST tool, which follows the methodology of the Finite Difference Time domain. The bottom layer is made of gold with 0.2 μm thick to prevent electromagnetic wave propagation. The ground layer's overall dimensions are 34 × 36 × 0.2 μm³, and its electrical conductivity is 4.56e + 07 S/m. The upper layer has a circle-shaped patch and several slots that are 0.2 μm thick. The overall sizes of the conducting patch are 32 × 32 × 0.2 μm³. A polyimide substance is inserted between the two layers. The height of the polyimide material is 7 μm, and its permittivity is 3.5. The middle layer has the overall dimensions of 34 × 36 × 7 μm³. Figure 1 shows a front view representation of the proposed unit cell. The dimensions (μm) of suggested design are P₁ = 32, P₂ = 32, S = 5, X = 2, Y = 2, Z = 5.5, a = 11, b = 9.5 and c = 5.

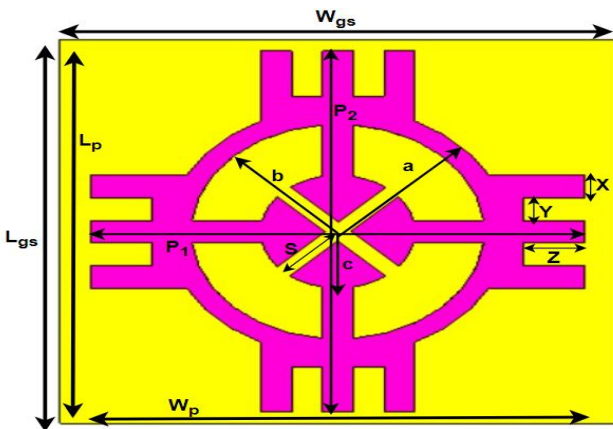

Fig. 1 – Front view representation of the proposed unit cell

The CST tool is used to solve electromagnetic problems that require quick and precise simulation results. This software's main benefit is that it has straightfor-

ward requirements for linear resource scaling in relation to the number of mesh nodes. This enables the simple and effective control of massive radiating structures. An effective and reliable 3D full-wave solver that is perfect for computing applications is the frequency domain solver. Figure 2 shows that the electromagnetic wave is impacted in a different way when the frequency is specified at the starting of the simulation and ideal E and H boundary conditions are applied to the x and y axes, respectively.

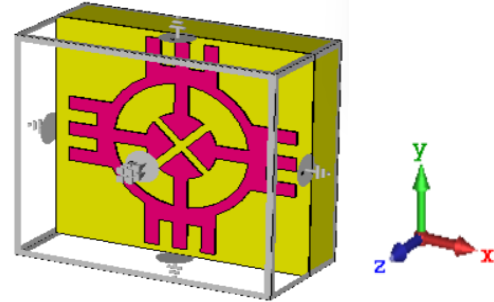

Fig. 2 – The proposed design's simulation setup

3. PARAMETRIC ANALYSIS

3.1 Impact of P₁ and P₂ Parameters

The split gap is the most important criterion for evaluating the effectiveness of any metamaterial-based structure. The structure's resonance frequency depends on the values of L and C parameters. Figure 3(a) shows the relative absorption after parametric analysis, with P₁ varying from 31 to 33 μm in 1 μm increments. P₁ = 31 μm and 33 μm yields the lowest absorption percentage. The maximum absorption % for the two resonant bands attained only at P₁ = 32 μm, as depicted in Figure 3(a). Figure 3(b) indicates the relative absorption in a similar manner when P₂ is changed from 31 to 33 μm with increment of 1 μm. The minimum absorption bandwidth is produced by P₂ = 31 μm and 33 μm. The maximum bandwidth and peak absorption percentage at two resonant bands are attained only at P₂ = 32 μm, as seen in Figure 3(b).

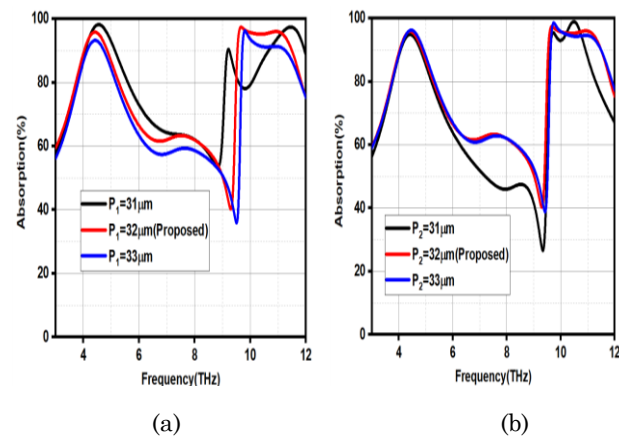

Fig. 3 – Absorption plots obtained through parametric analysis by altering (a) P₁ and (b) P₂ parameters

3.2 Impact of a and b Parameters

As with the geometric parameters a , b , and c , parametric analysis is carried out by adjusting the design parameters a from 10 to 12 μm and b from 9 to 10 μm with a step size of 1 and 0.5 μm , respectively. The relative reactions of the MMA are displayed in Figures 4(a) and 4(b), correspondingly. The absorption percentage is decreased at $a = 10$ and 12 μm . The highest absorption percentage at the two resonant bands is obtained only at $a = 11 \mu\text{m}$, as depicted in Figure 4(a). Figure 4(b) shows that the absorption percentages are highest at $b = 9.5 \mu\text{m}$ at the two resonant bands, while the minimum absorption level is reached at $b = 9$ and 10 μm .

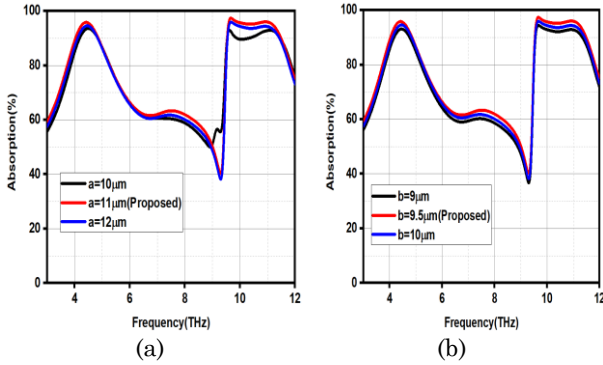

Fig. 4 – Absorption plots obtained through parametric analysis by altering (a) a and (b) b parameters

4. RESULTS AND DISCUSSION

Figure 5 shows the proposed structure's absorption and reflection spectrums. First resonance of the proposed design occurs at 4.4 THz with a 0.8 THz bandwidth (4 THz to 4.8 THz), while the proposed design additionally resonates at 9.6 THz with a 1.9 THz bandwidth (9.5 THz to 11.4 THz).

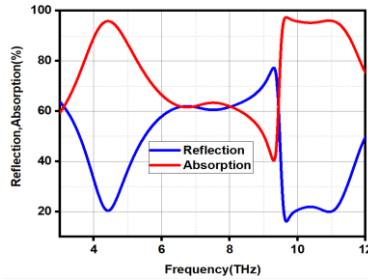

Fig. 5 – Spectrums of absorption and reflection for the proposed unit cell

For the TE mode, parametric analysis is used to improve the design for various polarization angles, ϕ is chosen from 0 to 80 degrees with 10-degree step size. The response to the pertinent analysis is displayed in Figure 6(a). A contour diagram that resembles Figure 6(a) is presented in Figure 6(b). The ϕ is measured along the y -axis, while the frequency is shown x -axis, which ranges from 3 to 12 THz. Figure 6(b) illustrates the impact of various polarization angles on the absorption. The percentages of absorption at two resonance frequencies are 96 % and 98 %, respectively. A constant absorption bandwidth is attained by the TE mode regardless of the polarization angle.

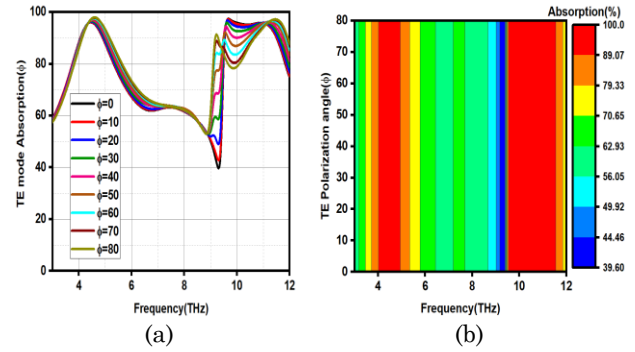

Fig. 6 – The obtained absorption (%) representation under TE mode in terms of ϕ using (a) spectrum (b) contour plot

The performance of the design can be assessed for different polarization angles by using parametric analysis for the TM mode to choose ϕ in 10-degree increments from 0 to 80 degrees. The pertinent graph as a function of polarization angle is depicted in Figure 7(a). Figure 7(b) shows the contour plot that was obtained from Figure 7(a). The effect of various polarization angles on the TM mode's absorption is seen in Figure 7(b). We achieve two different resonance frequencies with absorption rates of 96 % and 98 %. The absorption bandwidth in TM mode is independent of the polarization angle.

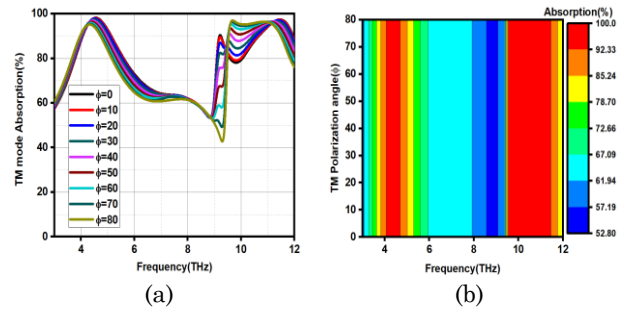

Fig. 7 – The obtained absorption (%) representation under TM mode in terms of ϕ using (a) spectrum (b) contour plot

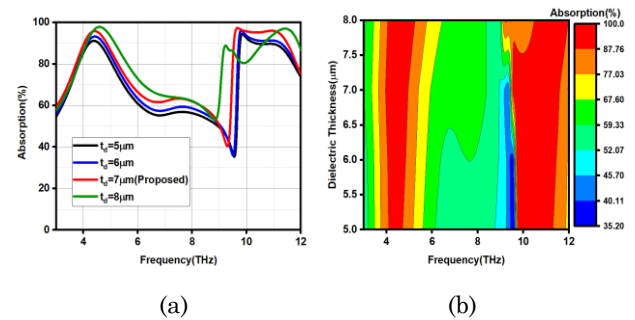

Fig. 8 – The obtained absorption (%) for different thicknesses of polyimide dielectric material (a) spectral and (b) contour plot

The structure can be evaluated parametrically with varying dielectric thickness values, ranging from 5 μm to 8 μm with 1 μm step-size. The structure's response is seen in Figure 8(a). Figure 8(b) illustrates a contour diagram similar to Figure 9(a). Figure 8(b) shows how the x and y axes are used to select the frequency parameters and dielectric material thickness. At two

resonant frequencies, the absorption % is decreased by choosing a dielectric thickness of 5, 6, and 8 μm . The only thickness at which the resonating bands exhibit their highest percentage of absorption is 7 μm .

5. FIELD DISTRIBUTION ANALYSIS

Any unit cell structure can be validated using the effective parameters of the E and H field distributions. Analyzing the unit cell's electric and magnetic fields can verify the design accuracy of the device. Figures 9 and 10 show that the inner circle and slots of the VO_2 patch provide a highest E -field at 4.4 THz, while the inner circle and corners of the patch's E -shape show a highest E -field at 9.6 THz. Maximum H -field is observed at 4.4 THz in the horizontal E -shaped patch and little inner circle. At 9.6 THz, a noticeable H -field is seen on the inner and outer circles as well as in E -shaped patch. Additionally, it can be concluded that the E and H fields are perpendicular to one another.

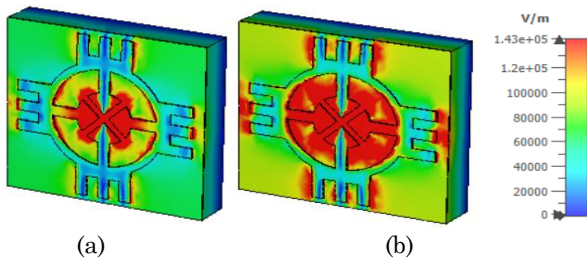

Fig. 9 – Distribution of E field for the proposed unit cell at (a) 4.4 THz (b) 9.6 THz

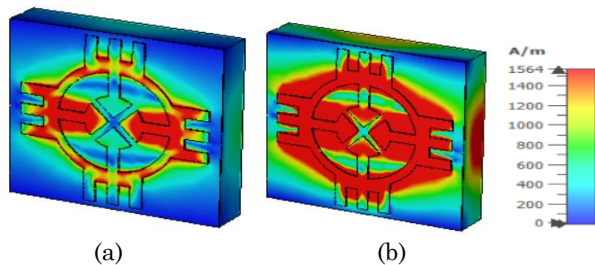

Fig. 10 – Distribution of H field for the proposed unit cell at (a) 4.4 THz (b) 9.6 THz

REFERENCES

- J. Fan, Y. Cheng, *J. Phys. D: Appl. Phys.* **53** No 2, 025109 (2020).
- D.X. Yan, M. Meng, J.S. Li, X. J. Li, *Front. Phys.* **8**, 306 (2020).
- A. Norouzi-Razani, P. Rezaei, *Micro Nanostruct.* **163**, 107153 (2022).
- G. Wang, T. Wu, J. Jiang, Y. Jia, Y. Gao, Y. Gao, *Diam. Relat. Mater.* **130**, 109460 (2022).
- N. Kumar, B. Suthar, Rostami, *Opt. Commun.* **529**, 129073 (2023).
- N.I. Landy, S. Sajuyigbe, J.J. Mock, D.R. Smith, W.J. Padilla, *Phys. Rev. Lett.* **100**, 207402 (2008).
- Y.K. Zou, H.Y. Lin, Y.K. Wu, H.X. Zhu, X.Y. Zhang, B.X. Wang, *J. Electron. Mater.* **52**, 2852 (2023).
- J. Huang, J.N. Li, Y. Yang, J. Li, J.H. Li, Y.T. Zhang, J.Q. Yao, *Opt. Express* **28** No 12, 17832 (2020).
- M. Pan, H.Z. Huang, B.D. Fan, W.Z. Chen, S. Li, Q.L. Xie, F. Xu, D.W. Wei, J. Fang, *Res. Phys.* **23**, 104037 (2021).
- F. Ding, S. Zhong, S.I. Bozhevolnyi, *Adv. Opt. Mater.* **6** No 9, 1701204 (2018).
- Y. Ren, T. Zhou, C. Jiang, B. Tang, *Opt. Express* **29** No 5, 7666 (2021).
- X. Huang, M. Cao, D.Q. Wang, X. Li, J. Fan, X. Li, *Opt. Mater. Express* **12** No 2, 811 (2022).
- Chenxi Liu, Yanlin Xu, Ruiqi Huang, Song Zha, *AIP Adv.* **13** No 9, 095204 (2023).
- Xiaoyan Wang, Yanfei Liu, Yilin Jia, Ningning Su, Qianann Wu, *Micromachines*, **14** No 7, 1381 (2023).
- Dong Mei Liu, Tu Jian Yun, Duo Lin Wang, Bo Chen, Hu Yao Hui, Jiu Fu Ruan, *Opt. Quant. Electron.* **56**, 1144 (2024).
- Yan Liu, Lingxi Hu, Ming Liu, *Nanomaterials* **14** No 14, 1200 (2024).
- Maixia Fu, Na Xia, Yule Duan, Fei Zhou, Yinsheng Li, *AIP Adv.* **14**, 025210 (2024).

6. PERFORMANCE COMPARISON WITH STATE OF THE ART

A comparison of current research with the state of the art is shown in Table 1. According to the comparison table, the metasurface absorber exhibits a dual-band absorption rate over 95 percent. This micro structure contains two resonant bands with 96 % and 98 % absorption, respectively, and it shows polarization-insensitive features up to 80 degrees, according to Table 1.

Table 1. Comparison of present work with existing Research

Ref.	2D Unit cell size (μm^2)	Conducting Patch	Absorption (%)	Absorption Bandwidth (THz)
[3]	60×60	Graphene	98	1.48-3.65 (2.17)
[4]	35×35	Graphene and VO_2	95	0.8-2.4 (1.6)
[13]	65×65	VO_2	90, 90	Not Mentioned
[14]	22×22	VO_2	90	3.8-15.6 (11.8)
This Work	34×36	VO_2	96, 98	4-4.85(0.85), 9.5-11.4(1.9)

7. CONCLUSION

In this article, a polarization-insensitive metamaterial absorber based on VO_2 is presented for terahertz applications. The suggested unit cell has dimensions of $34 \times 36 \times 7.4 \mu\text{m}^3$ and provides two separate absorption peaks with bandwidths of 4 to 4.8 THz and 9.5 to 11.4 THz, respectively, at resonance frequencies of 4.4 and 9.68 THz. In the corresponding dual resonant bands, the structure has absorption rates of 96 % and 98 %. It is confirmed that the suggested design is polarization insensitive and changing polarization angles have an impact on absorbance for both TE and TM modes. Additionally, the impact of different incidence angles on absorption is described. Consequently, the suggested dual-band VO_2 -based absorber is strongly recommended for cloaking, imaging, detection and electromagnetic shielding.

Двосмуговий поляризаційно-нечутливий метаматеріальний поглинач на основі діоксиду ванадію для терагерцових застосувань

Mahesh Valathuru¹, Pokkunuri Pardhasaradhi¹, Suresh Dannana²,
Nagandla Prasad², B.T.P. Madhav¹, Sudipta Das³

¹ *ALRC Research Centre, Department of ECE, Koneru Lakshmaiah Education Foundation, Guntur, Andhra Pradesh, India*

² *Department of Electronics and Communication Engineering, GMR Institute of Technology, Rajam, 532127 Andhra Pradesh, India*

³ *Department of Electronics and Communication Engineering, IMPS College of Engineering and Technology, Malda 732103 West Bengal, India*

Метою цього дослідження є ретельне проектування та аналіз метаматеріальних поглиначів ТГц на основі діоксиду ванадію (VO₂). Тришарові конструкції запропонованих метаматеріальних поглиначів (ММА) включають випромінюючий елемент з діоксиду ванадію (VO₂) товщиною 0,2 мкм, діелектричну підкладку з поліімиду з діелектричною проникністю 3,5 та заземлювальний провідний шар золота (Au) з електропровідністю $4,56e + 0,7$ См/м для запобігання поширенню електромагнітних хвиль. Загальний розмір запропонованої структури становить $34 \times 36 \times 7,4$ мкм³. Дві пікові частоти поглинання, на яких працює елементарний елементарний ММА, становлять 4,4 ТГц та 9,68 ТГц. Максимальні відсотки поглинання в робочих діапазонах частот становлять 96 % та 98 %, і вони охоплюють діапазон від 4 до 4,8 ТГц та від 9,5 до 11,4 ТГц відповідно. Дуже корисно зрозуміти явища провідності випромінюючої плями VO₂, щоб досягти високого відсотка поглинання для відповідної смуги частот поглинання. Крім того, перевіряється нечутливість поглинання до кута поляризації. Додатково проводиться параметричний аналіз для різних конструктивних параметрів на поглинальну характеристику запропонованого поглинача. Крім того, представлено вплив кута поляризації на поглинання для ТЕ- та ТМ-мод. Запропонований двосмуговий терагерцовий поглинач може бути придатним для маскування, візуалізації, детектування та електромагнітного екранування.

Ключові слова: Абсорбент, Метаматеріал, Діоксид ванадію (VO₂).